



# USB2000+ Fiber Optic Spectrometer

## Installation and Operation Manual

Document Number 270-00000-000-02-0108

**Offices:** **Ocean Optics, Inc. World Headquarters**  
830 Douglas Ave., Dunedin, FL, USA 34698  
Phone 727.733.2447  
Fax 727.733.3962  
8 a.m.– 8 p.m. (Mon–Thu), 8 a.m.– 6 p.m. (Fri) EST

---

**E-mail:** **Info@OceanOptics.com** (General sales inquiries)  
**Orders@OceanOptics.com** (Questions about orders)  
**TechSupport@OceanOptics.com** (Technical support)

—A—  
**HALMA**  
**GROUP**  
**COMPANY**

**Additional  
Offices:**

**Ocean Optics Asia**

**666 Gubei Road, Kirin Tower, Suite 601B, Changning District, Shanghai,  
PRC. 200051**

**Phone 86.21.6295.6600**

**Fax 86.21.6295.6708**

**E-Mail Sun.Ling@OceanOptics.com**

**Ocean Optics B.V. (Europe)**

**Geograaf 24, 6921 EW DUIVEN, The Netherlands**

**Phone 31-(0)26-319 0500**

**Fax 31-(0)26-319 0505**

**E-Mail Info@OceanOpticsBV.com**

**Copyright © 2001-2007 Ocean Optics, Inc.**

All rights reserved. No part of this publication may be reproduced, stored in a retrieval system, or transmitted, by any means, electronic, mechanical, photocopying, recording, or otherwise, without written permission from Ocean Optics, Inc.

This manual is sold as part of an order and subject to the condition that it shall not, by way of trade or otherwise, be lent, re-sold, hired out or otherwise circulated without the prior consent of Ocean Optics, Inc. in any form of binding or cover other than that in which it is published.

**Trademarks**

All products and services herein are the trademarks, service marks, registered trademarks or registered service marks of their respective owners.

**Limit of Liability**

Every effort has been made to make this manual as complete and as accurate as possible, but no warranty or fitness is implied. The information provided is on an "as is" basis. Ocean Optics, Inc. shall have neither liability nor responsibility to any person or entity with respect to any loss or damages arising from the information contained in this manual.

# Table of Contents

About This Manual .....	iii
Document Purpose and Intended Audience.....	iii
Document Summary.....	iii
Product-Related Documentation .....	iii
Upgrades.....	iv
Service .....	iv
<b>Chapter 1: Introduction .....</b>	<b>1</b>
Product Overview .....	1
Features .....	2
System Requirements .....	2
EEPROM Utilization .....	2
About SpectraSuite.....	2
Sampling System Overview.....	3
How Sampling Works.....	3
Interface Options .....	3
Shipment Components.....	3
Additional Equipment Needed.....	4
Other Accessories Available .....	4
<b>Chapter 2: Installing the USB2000+.....</b>	<b>6</b>
Overview .....	6
USB2000+ Installation.....	6
USB Mode .....	6
Serial Port Mode.....	7
Connect Spectroscopic Accessories .....	7
USB2000+ Configuration.....	7
Configuring the USB2000+ in SpectraSuite .....	7
Configuring the USB2000+ in OOIBase32.....	8

<b>Chapter 3: Troubleshooting .....</b>	<b>9</b>
Overview .....	9
USB2000+ Connected to Computer Prior to SpectraSuite Installation .....	9
Windows Operating Systems .....	9
Remove the Unknown Device from Windows Device Manager .....	9
Remove Improperly Installed Files.....	10
Mac Operating Systems .....	10
Linux Operating Systems .....	11
<b>Appendix A: Calibrating the Wavelength of the USB2000+ .....</b>	<b>13</b>
Overview .....	13
About Wavelength Calibration .....	13
Calibrating the Spectrometer.....	14
Preparing for Calibration.....	14
Calibrating the Wavelength of the Spectrometer .....	14
Saving the New Calibration Coefficients: USB Mode .....	16
<b>Appendix B: External Triggering .....</b>	<b>17</b>
Overview .....	17
Normal (Free Running).....	17
External Software Trigger.....	17
External Hardware Trigger .....	17
External Synchronization Trigger .....	18
<b>Appendix C: Specifications.....</b>	<b>19</b>
Overview .....	19
How the USB2000+ Works.....	19
USB2000+ Components Table.....	20
USB2000+ Specifications.....	21
20-Pin Accessory Connector Pinout.....	22
20-Pin Accessory Connector Pinout Diagram.....	22
20-Pin Accessory Connector – Pin Definitions and Descriptions.....	22
<b>Index.....</b>	<b>25</b>

---

# About This Manual

## Document Purpose and Intended Audience

This document provides the users of USB2000+ Spectrometers with instructions for setting up, calibrating and performing experiments with their spectrometer.

## Document Summary

Chapter	Description
Chapter 1: <a href="#">Introduction</a>	Contains descriptive information about the USB2000+ Spectrometer and how sampling works. It also provides a list of system requirements, interface options, and shipment components.
Chapter 2: <a href="#">Installing the USB2000+</a>	Provides installation instructions.
Chapter 3: <a href="#">Troubleshooting</a>	Contains recommended steps to isolate and correct common problems.
Appendix A: <a href="#">Calibrating the Wavelength of the USB2000+</a>	Provides instructions for calibrating the USB2000+ Spectrometer.
Appendix B: <a href="#">External Triggering</a>	Contains information about external triggering for the USB2000+.
Appendix C: <a href="#">Specifications</a>	Contains technical specifications and connector pinouts for the USB2000+ Spectrometer.

## Product-Related Documentation

You can access documentation for Ocean Optics products by visiting our website at <http://www.oceanoptics.com>. Select *Technical* → *Operating Instructions*, then choose the appropriate document from the available drop-down lists. Or, use the **Search by Model Number** field at the bottom of the web page.

- Detailed instructions for SpectraSuite Spectrometer Operating Software are located at: <http://www.oceanoptics.com/technical/SpectraSuite.pdf>.
- Detailed instructions for the Breakout Box are located at: [http://www.oceanoptics.com/technical/HR4\\_breakout.pdf](http://www.oceanoptics.com/technical/HR4_breakout.pdf).
- Detailed instructions for external triggering are located at: <http://www.oceanoptics.com/technical/external-triggering.pdf>.

Engineering-level documentation is located on our website at *Technical* → *Engineering Docs*.

You can also access operating instructions for Ocean Optics products from the *Software and Technical Resources* CD that ships with the product.

## Upgrades

Occasionally, you may find that you need Ocean Optics to make a change or an upgrade to your system. To facilitate these changes, you must first contact Customer Support and obtain a Return Merchandise Authorization (RMA) number. Please contact Ocean Optics for specific instructions when returning a product.

## Service

Our Total Technical Service protection plans protect your spectrometer for one year for any contingency - no matter what the circumstances, including total loss. Under these plans, Ocean Optics will repair or replace your instrument with no deductible or any other out-of-pocket expense required from you. USB service plans include the following:

- **TTS-USB:** Protects your Ocean Optics USB spectrometer for any contingency for 1 year. Provides for full spectrometer replacement, if necessary. Limited to 1 full replacement per year.
- **TTS-USB-E:** This special plan for Ocean Optics USB spectrometers not previously covered protects for any contingency for 1 year. Provides for full spectrometer replacement, if necessary. Limited to 1 full replacement per year. This coverage starts 30 days after purchasing the plan.

In addition, we also have the WAVECAL-USB spectrometer maintenance and calibration service available to recalibrate, clean and perform any adjustments necessary on your USB2000+ Spectrometer.

Contact us to learn more about these great service plans.

---

# Chapter 1

# Introduction

## Product Overview

The USB2000+ Miniature Fiber Optic Spectrometer is a unique combination of technologies a powerful 2-MHz analog-to-digital (A/D) converter, programmable electronics, a 2048-element CCD-array detector, and a high-speed USB 2.0 port. This innovative combination produces our fastest spectrometer yet and provides resolution to 0.35 nm (FWHM). The USB2000+ allows users to capture and store a full spectrum into memory every millisecond (that's 1,000 full spectra every second) when the spectrometer is interfaced to a computer via a USB 2.0 port. The USB2000+ is perfect for chemical, biochemical and other applications where fast reactions need to be monitored.

The USB2000+ Spectrometer connects to a computer via the USB port or serial port. When connected through a USB 2.0 or 1.1, the spectrometer draws power from the host computer, eliminating the need for an external power supply. The USB2000+, like all USB devices, can be controlled by our SpectraSuite software, a completely modular, Java-based spectroscopy software platform that operates on Windows, Macintosh and Linux operating systems.



**Ocean Optics USB2000+ Fiber Optic Spectrometer Typical Set-up**

# Features

- ❑ Sony ILX511 2048-element linear silicon CCD array detector
- ❑ Responsive from 200 to 1100 nm
- ❑ Sensitivity of up to 75 photons/count at 400 nm; 41 photons/count at 600 nm
- ❑ An optical resolution of ~10.0 nm (FWHM)
- ❑ Integration times from 3 ms to 65 seconds
- ❑ EEPROM storage for
  - Wavelength Calibration Coefficients
  - Linearity Correction Coefficients
  - Absolute Irradiance Calibration (optional)
- ❑ Low power consumption of only 250 mA @ 5 VDC
- ❑ 16 bit, 3MHz A/D Converter
- ❑ 5 triggering modes
- ❑ 20-pin connector for interfacing to external products
- ❑ CE Certification
- ❑ RoHS compliant

# System Requirements

You can use the USB2000+'s USB connectivity with any computer that meets the following requirements:

- Operating system is one of the following:
  - Windows – 98/Me/2000/XP
  - Apple Macintosh – OS X version 10.0 or later
  - Linux – Red Hat 9 or later, Fedora (any version), Debian 3.1 (Sarge), and SUSE (9.0 or later)
- Ocean Optics' SpectraSuite software application installed and configured for use.

# EEPROM Utilization

An EEPROM memory chip in each USB2000+ contains wavelength calibration coefficients, linearity coefficients, and a serial number unique to each individual spectrometer. The SpectraSuite software application reads these values directly from the spectrometer, enabling the ability to “hot-swap” spectrometers between computers without entering the spectrometer coefficients manually on each computer.

# About SpectraSuite

SpectraSuite is the latest generation of operating software for all Ocean Optics spectrometers. It is a completely modular, Java-based spectroscopy software platform that operates on Windows, Macintosh and Linux operating systems. The software can control any Ocean Optics USB spectrometer and device, as well as any other manufacturer's USB instrumentation using the appropriate drivers.

SpectraSuite is a user-customizable, advanced acquisition and display program that provides a real-time interface to a variety of signal-processing functions. With SpectraSuite, you have the ability to perform spectroscopic measurements (such as absorbance, reflectance, and emission), control all system parameters, collect and display data in real time, and perform reference monitoring and time acquisition experiments. Consult the SpectraSuite manual for hardware requirements when using SpectraSuite (see [Product-Related Documentation](#)).

## Sampling System Overview

### How Sampling Works

Ocean Optics components function in a sampling system as follows:

1. The user stores reference and dark measurements to correct for instrument response variables.
2. The light from the light source transmits through an optical fiber to the sample.
3. The light interacts with the sample.
4. Another optical fiber collects and transmits the result of the interaction to the spectrometer.
5. The spectrometer measures the amount of light and transforms the data collected by the spectrometer into digital information.
6. The spectrometer passes the sample information to SpectraSuite.
7. SpectraSuite compares the sample to the reference measurement and displays processed spectral information.

## Interface Options

The USB2000+ has both USB and serial port connectors (with the use of an adapter), enabling you to connect the spectrometer to a computer via a USB or serial port. However, you must create custom software if using the serial port. SpectraSuite software is available if you are connecting via the USB port.

## Shipment Components

The following information and documentation ships with the USB2000+ Spectrometer:

#### ❑ **Packing List**

The packing list is inside a plastic bag attached to the outside of the shipment box (the invoice arrives separately). It lists all items in the order, including customized components in the spectrometer (such as the grating, detector collection lens, and slit). The packing list also includes the shipping and billing addresses, as well as any items on back order.

#### ❑ **USB Cable (USB-CBL-1)**

Use this cable to connect your spectrometer to a computer running on a Windows, Mac or Linux operating system.

## 1: Introduction

---

### ❑ **Wavelength Calibration Data Sheet**

Each spectrometer is shipped with a Wavelength Calibration Data Sheet that contains information unique to your spectrometer. SpectraSuite Operating Software reads this calibration data from your spectrometer when it interfaces to a computer via the USB port.

---

### **Note**

Please save the Wavelength Calibration Data Sheet for future reference.

---

### ❑ **Software and Technical Resources CD**

Each order ships with the Ocean Optics *Software and Resources CD*. This disc contains software, operating instructions, and product information for all Ocean Optics software, spectrometers, and spectroscopic accessories. You need Adobe Acrobat Reader version 6.0 or higher to view these files. Ocean Optics includes the Adobe Acrobat Reader on the *Software and Technical Resources CD*.

Ocean Optics software requires a password during the installation process. You can locate passwords for the other software applications on the back of the *Software and Technical Resources CD* package.

## Additional Equipment Needed

### ❑ **SpectraSuite Operating Software**

See [About SpectraSuite](#) for more information.

## Other Accessories Available

Visit us at [www.OceanOptics.com](http://www.OceanOptics.com) for a complete list of products available for all of your spectroscopy needs.

- ❑ **Fibers**
- ❑ **Light Sources**
- ❑ **Integrated Sampling Systems**
- ❑ **Cuvettes**
- ❑ **Filter Holders**



# Installing the USB2000+

## Overview

You must install the SpectraSuite software application prior to connecting the USB2000+ Spectrometer to the computer. The SpectraSuite software installation installs the drivers required for USB2000+ installation. If you do not install SpectraSuite first, the system will not properly recognize the USB2000+.

If you have already connected the USB2000+ to a computer running on a Windows platform prior to installing SpectraSuite, consult *Chapter 3: [Troubleshooting](#)* for information on correcting a corrupt USB2000+ installation.

Note the spectrometer(s) that you have installed are listed in the Data Sources pane.

## USB2000+ Installation

This section contains instructions for connecting the USB2000+ via both USB and serial modes.

### USB Mode

---

#### Note

The USB port on a computer can power up to five USB2000+ spectrometer channels. Systems with more than five channels require a powered USB hub.

---

#### ► Procedure

Follow the steps below to connect the USB2000+ to a computer via the USB port:

1. Install SpectraSuite on the destination computer.
2. Locate the USB cable (USB-CBL-1) provided with the USB2000+.
3. Insert the square end of the cable into the side of the USB2000+.
4. Insert the rectangular end of the cable into the USB port of the computer.

If you installed SpectraSuite prior to connecting the USB2000+, the SpectraSuite installs the USB2000+ drivers. If the drivers do not successfully install (or if you connected the USB2000+ to the computer before installing SpectraSuite), consult *Chapter 3: [Troubleshooting](#)*.

If you have followed the previous steps and started SpectraSuite, the spectrometer is already acquiring data. Even with no light in the spectrometer, there should be a dynamic trace displayed in the bottom of the graph. If you allow light into the spectrometer, the graph trace should rise with increasing light intensity. This means the software and hardware are correctly installed.

Note the spectrometer(s) that you have installed are listed in the Data Sources pane.

Once you install the software and hardware, and establish your sampling system, you are ready to take measurements.

## Serial Port Mode

To use the serial port capacity of the USB2000+ Spectrometer, the computer must be running a 32-bit version of the Windows operating system.

### ► Procedure

Follow the steps below to connect the USB2000+ to the computer via serial port:

1. Connect the serial cable adapter block to the appropriate pins of the USB2000+'s 30-Pin Accessory Connector.
2. Connect one end of the 9-pin serial cable to the adapter block on the USB2000+, and then connect the other end to a serial port on the computer.
3. Note the number of the serial port (COM Port) to which you connected the USB2000+ (some computers may not have numbered ports; handheld computers typically have only one serial port).
4. Plug the 5 VDC external power supply into an outlet and connect it to the USB2000+.

## Connect Spectroscopic Accessories

To find operating instructions for USB2000+-compatible products (such as light sources, sampling chambers, and probes), consult the *Software and Technical Resources* CD or the Ocean Optics website at <http://www.oceanoptics.com/technical/operatinginstructions.asp>.

## USB2000+ Configuration

The USB2000+ can be used with either SpectraSuite or OOIBase32 software when connected to the USB port. The configuration process differs, depending on whether you are running SpectraSuite or OOIBase32 software.

### Configuring the USB2000+ in SpectraSuite

If you have followed the previous steps and started SpectraSuite, the spectrometer is already acquiring data. Even with no light in the spectrometer, there should be a dynamic trace displayed in the bottom of the graph. If you allow light into the spectrometer, the graph trace should rise with increasing light intensity. This means the software and hardware are correctly installed.

## 2: Installing the USB2000+

---

Note the spectrometer(s) that you have installed are listed in the Data Sources pane.

# Configuring the USB2000+ in OOIBase32

Once you install the USB2000+, you must configure OOIBase32's **Configure Spectrometer** options so that OOIBase32 recognizes the USB2000+ Spectrometer. Consult the *OOIBase32 Spectrometer Operating Software Operating Instructions* for detailed instructions on configuring the spectrometer in OOIBase32 (see [Product-Related Documentation](#)).

# Troubleshooting

## Overview

The following sections contain information on troubleshooting issues you may encounter when using the USB2000+ Spectrometer.

## USB2000+ Connected to Computer Prior to SpectraSuite Installation

### Windows Operating Systems

If you connected your Ocean Optics USB2000+ device to the computer prior to installing your Ocean Optics software application on a Windows platform, you may encounter installation issues that you must correct before your Ocean Optics device will operate properly.

Follow the applicable steps below to remove the incorrectly installed device, device driver, and installation files.

---

#### Note

If these procedures do not correct your device driver problem, you must obtain the *Correcting Device Driver Issues* document from the Ocean Optics website:  
<http://www.oceanoptics.com/technical/engineering/correctingdevicedriverissues.pdf>.

---

### Remove the Unknown Device from Windows Device Manager

#### ► Procedure

1. Open Windows Device Manager. Consult the Windows operating instructions for your computer for directions, if needed.
2. Locate the **Other Devices** option and expand the **Other Devices** selection by clicking on the "+" sign to the immediate left.

---

### Note

Improperly installed USB devices can also appear under the Universal Serial Bus Controller option. Be sure to check this location if you cannot locate the unknown device.

---

3. Locate the unknown device (marked with a large question mark). Right-click on the **Unknown Device** listing and select the **Uninstall** or **Remove** option.
4. Click the **OK** button to continue. A warning box appears confirming the removal of the Unknown Device. Click the **OK** button to confirm the device removal.
5. Disconnect the USB2000+ from your computer.
6. Locate the section in this chapter that is appropriate to your operating system and perform the steps in the following [Remove Improperly Installed Files](#) section.

## Remove Improperly Installed Files

### ► Procedure

1. Open Windows Explorer.
2. Navigate to the **Windows | INF** directory.

---

### Note

If the INF directory is not visible, you must disable the Hide System Files and Folders and Hide File Extensions for Known File Types options in Windows Folder Options. Access Windows Folder Options from Windows Explorer, under the **Tools | Folder Options** menu selection.

---

3. Delete the **OOI\_USB.INF** in the INF directory. If your computer is running either the Windows 2000 or XP operating system, you must also delete the **OOI\_USB.PNF** file in the INF directory.
4. Navigate to the **Windows | System32 | Drivers** directory.
5. Delete the **EZUSB.SYS** file.
6. Reinstall your Ocean Optics application and reboot the system when prompted.
7. Plug in the USB device.

The system is now able to locate and install the correct drivers for the USB device.

## Mac Operating Systems

Since there are no device files for the USB2000+ Spectrometer in a Mac operating system, you should not encounter any problems if you installed the spectrometer before the SpectraSuite software.

## Linux Operating Systems

For Linux operating systems, all you need to do is install the SpectraSuite software, then unplug and replug in the spectrometer. Technically, the driver files for Linux simply give nonprivileged users permission to use newly connected hardware. There isn't any long-term harm to plugging in the device before installing the software.



---

## Appendix A

# Calibrating the Wavelength of the USB2000+

## Overview

This appendix describes how to calibrate the wavelength of your spectrometer. Though each spectrometer is calibrated before it leaves Ocean Optics, the wavelength for all spectrometers will drift slightly as a function of time and environmental conditions. Ocean Optics recommends periodically recalibrating the USB2000+.

## About Wavelength Calibration

You are going to be solving the following equation, which shows that the relationship between pixel number and wavelength is a third-order polynomial:

$$\lambda_p = I + C_1p + C_2p^2 + C_3p^3$$

Where:

$\lambda$  = the wavelength of pixel  $p$

$I$  = the wavelength of pixel 0

$C_1$  = the first coefficient (nm/pixel)

$C_2$  = the second coefficient (nm/pixel<sup>2</sup>)

$C_3$  = the third coefficient (nm/pixel<sup>3</sup>)

You will be calculating the value for  $I$  and the three  $C$ s.

# Calibrating the Spectrometer

## Preparing for Calibration

To recalibrate the wavelength of your spectrometer, you need the following components:

- A light source capable of producing spectral lines

---

### Note

Ocean Optics' HG-1 Mercury-Argon lamp is ideal for recalibration. If you do not have an HG-1, you need a light source that produces several (at least 4-6) spectral lines in the wavelength region of your spectrometer.

- 
- A USB2000+ spectrometer
  - An optical fiber (for spectrometers without a built-in slit, a 50- $\mu\text{m}$  fiber works best)
  - A spreadsheet program (Excel or Quattro Pro, for example) or a calculator that performs third-order linear regressions

---

### Note

If you are using Microsoft Excel, choose **Tools | Add-Ins** and check **AnalysisToolPak** and **AnalysisToolPak-VBA**.

---

## Calibrating the Wavelength of the Spectrometer

### ► Procedure

Perform the steps below to calibrate the wavelength of the spectrometer:

1. Place SpectraSuite into Scope mode and take a spectrum of your light source. Adjust the integration time (or the A/D conversion frequency) until there are several peaks on the screen that are not off-scale.
2. Move the cursor to one of the peaks and position the cursor so that it is at the point of maximum intensity.
3. Record the pixel number that is displayed in the status bar or legend (located beneath the graph). Repeat this step for all of the peaks in your spectrum.
4. Use the spreadsheet program or calculator to create a table like the one shown in the following figure. In the first column, place the exact or true wavelength of the spectral lines that you used. In the second column of this worksheet, place the observed pixel number. In the third column, calculate the pixel number squared, and in the fourth column, calculate the pixel number cubed.

Independent Variable	Dependent Variables			Values Computed from the Regression Output	
True Wavelength (nm)	Pixel #	Pixel # <sup>2</sup>	Pixel # <sup>3</sup>	Predicted Wavelength	Difference
253.65	175	30625	5359375	253.56	0.09
296.73	296	87616	25934336	296.72	0.01
302.15	312	97344	30371328	302.40	-0.25
313.16	342	116964	40001688	313.02	0.13
334.15	402	161604	64964808	334.19	-0.05
365.02	490	240100	117649000	365.05	-0.04
404.66	604	364816	220348864	404.67	-0.01
407.78	613	375769	230346397	407.78	0.00
435.84	694	481636	334255384	435.65	0.19
546.07	1022	1044484	1067462648	546.13	-0.06
576.96	1116	1245456	1389928896	577.05	-0.09
579.07	1122	1258884	1412467848	579.01	0.06
696.54	1491	2223081	3314613771	696.70	-0.15
706.72	1523	2319529	3532642667	706.62	0.10
727.29	1590	2528100	4019679000	727.24	0.06
738.40	1627	2647129	4306878883	738.53	-0.13
751.47	1669	2785561	4649101309	751.27	0.19

- Use the spreadsheet or calculator to calculate the wavelength calibration coefficients. In the spreadsheet program, find the functions to perform linear regressions.
  - If using Quattro Pro, look under **Tools | Advanced Math**
  - If using Excel, look under **Analysis ToolPak**
- Select the true wavelength as the dependent variable (Y). Select the pixel number, pixel number squared, and the pixel number cubed as the independent variables (X). After executing the regression, you will obtain an output similar to the one shown below. Numbers of importance are noted.

**Regression Statistics**

Multiple R 0.999999831  
 R Square 0.999999663 ← R Squared  
 Adjusted R Square 0.999999607  
 Standard Error 0.125540214  
 Observations 22

	<u>Coefficients</u>	<u>Standard Error</u>	
Intercept	190.473993	0.369047536	← First coefficient
X Variable 1	0.36263983	0.001684745	← Second coefficient
X Variable 2	-1.174416E-05	8.35279E-07	
X Variable 3	-2.523787E-09	2.656608E-10	← Third coefficient

7. Record the Intercept, as well as the First, Second, and Third Coefficients. Additionally, look at the value for R squared. It should be very close to 1. If not, you have most likely assigned one of your wavelengths incorrectly.

Keep these values at hand.

## Saving the New Calibration Coefficients: USB Mode

Ocean Optics programs wavelength calibration coefficients unique to each USB2000+ onto an EEPROM memory chip in the USB2000+.

You can overwrite old calibration coefficients on the EEPROM if you are using the USB2000+ via the USB port.

### ► Procedure

To save wavelength calibration coefficients using the USB mode, perform the following steps:

1. Ensure that the USB2000+ is connected to the computer and that you have closed all other applications.
2. Point your browser to <http://www.oceanoptics.com/technical/softwaredownloads.asp> and scroll down to **Microcode**. Select **USB EEPROM Programmer**.
3. Save the setup file to your computer.
4. Run the **Setup.exe** file to install the software. The **Welcome** screen appears.
5. Click the **Next** button. The **Destination Location** screen appears.
6. Accept the default installation location, or click the **Browse** button to specify a directory. Then, click the **Next** button. The **Program Manager Group** screen appears.
7. Click the **Next** button. The **Start Installation** screen appears.
8. Click the **Next** button to begin the installation. Once the installation finishes, the **Installation Complete** screen appears.
9. Click the **Finish** button and reboot the computer when prompted.
10. Navigate to the **USB EEPROM Programmer** from the Start menu and run the software.
11. Click on the desired USB2000+ device displayed in the left pane of the **USB Programmer** screen.
12. Double-click on each of the calibration coefficients displayed in the right pane of the USB Programmer screen and enter the new values acquired in Steps 5 and 6 of the [Calibrating the Wavelength of the Spectrometer](#) section in this appendix.
13. Repeat Step 12 for all of the new values.
14. Click on the **Save All Values** button to save the information, and then **Exit** the USB Programmer software.

The new wavelength calibration coefficients are now loaded onto the EEPROM memory chip on the USB2000+.

# External Triggering

## Overview

The USB2000+ supports four triggering modes, which are set with the Trigger Mode command. Details of each triggering mode follow.

### Normal (Free Running)

In this mode, the USB2000+ uses the user-defined integration clock and continuously scans the CCD array. All of the signals described in the previous section are provided by the spectrometer to the CCD automatically based on the integration time selected in the software by the user.

### External Software Trigger

In this mode, the ExtTrigIn signal acts as an enable switch. If ExtTrigIn is kept HIGH, the USB2000+ will acquire spectra as if it was in the normal free running mode. If ExtTrigIn is kept LOW, the USB2000+ will not acquire spectra.

### External Hardware Trigger

On the USB2000+, Ocean Optics has altered the functionality of the External Hardware Trigger function and reprogrammed the Single Strobe signal function. These alterations of the USB2000 enable you to operate in the Variable Delay Mode without the presence of an external trigger signal. The USB2000+ will simulate the signal to trigger the appropriate circuitry in the spectrometer.

The table below summarizes the capacity of the USB2000+ in Variable Delay Mode:

Parameter	Value in Normal Acquisition Mode	Value in Variable Delay Mode
Integration time	User controlled	5 ms fixed
Strobe delay	0 $\mu$ s	2 – 511 $\mu$ s + 3 $\mu$ s
Jitter	< 25 ns	< 25 ns

## B: External Triggering

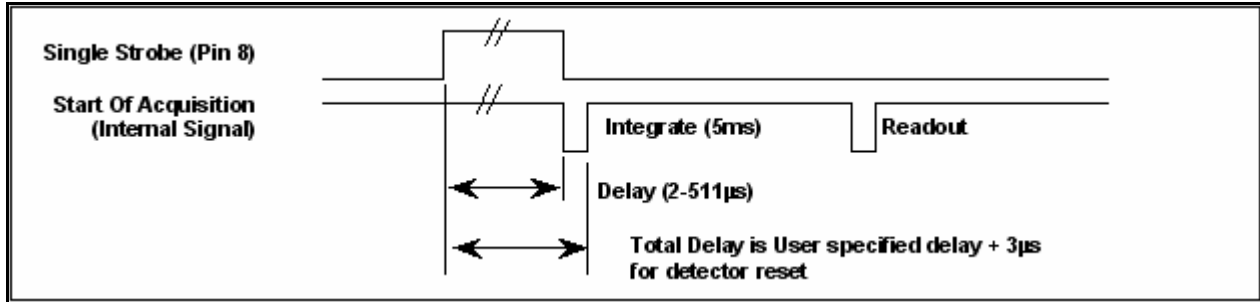

Timing Diagram for Variable Delay Mode

## External Synchronization Trigger

In this mode of the USB2000+, the integration clock is essentially input into the spectrometer. The synchronized trigger must have a frequency range of 5ms to 60s (shutter mode cannot be used in External Synchronization Trigger mode). If no External Trigger Input Signal is applied, the spectrometer will not take any spectra, and the software will appear “frozen” until an External Trigger Input Signal is detected. With a continuous ExtTrigIn, the spectrometer will provide the required signals to the CCD as shown below:

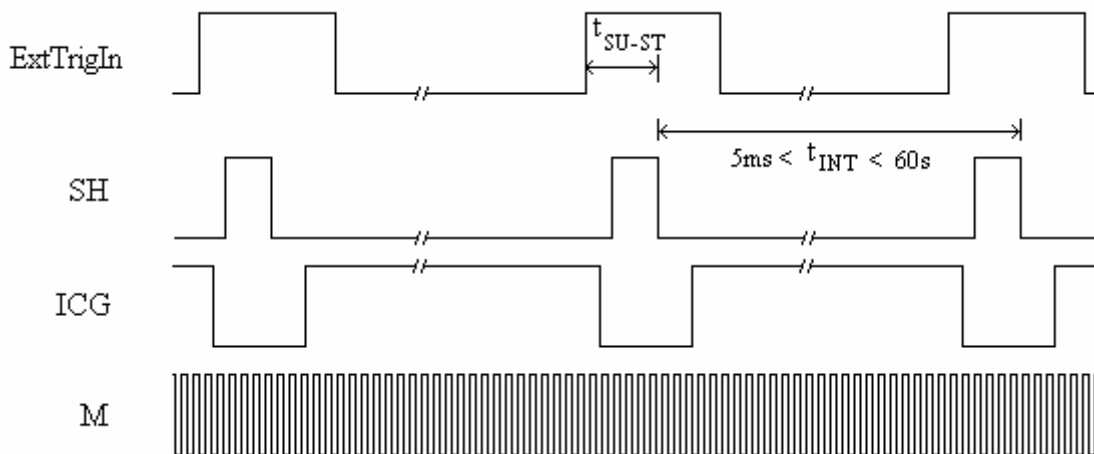

### External Synchronization Trigger

The time between when ExtTrigIn goes HIGH and the beginning of the integration period is specified to be between  $8\mu\text{s} < t_{\text{SU-ST}} < 10\mu\text{s}$ . The ExtTrigIn signal does not need to have an even duty cycle, but the time between rising edges should remain constant for a given integration time.

---

# Appendix C

# Specifications

## Overview

This appendix contains information on spectrometer operation, specifications, and system compatibility. It also includes accessory connector pinout diagrams and pin-specific information.

## How the USB2000+ Works

Below is a diagram of how light moves through the optical bench of an USB2000+ Spectrometer. The optical bench has no moving parts that can wear or break; all the components are fixed in place at the time of manufacture. Items with an asterisk (\*) are user-specified.

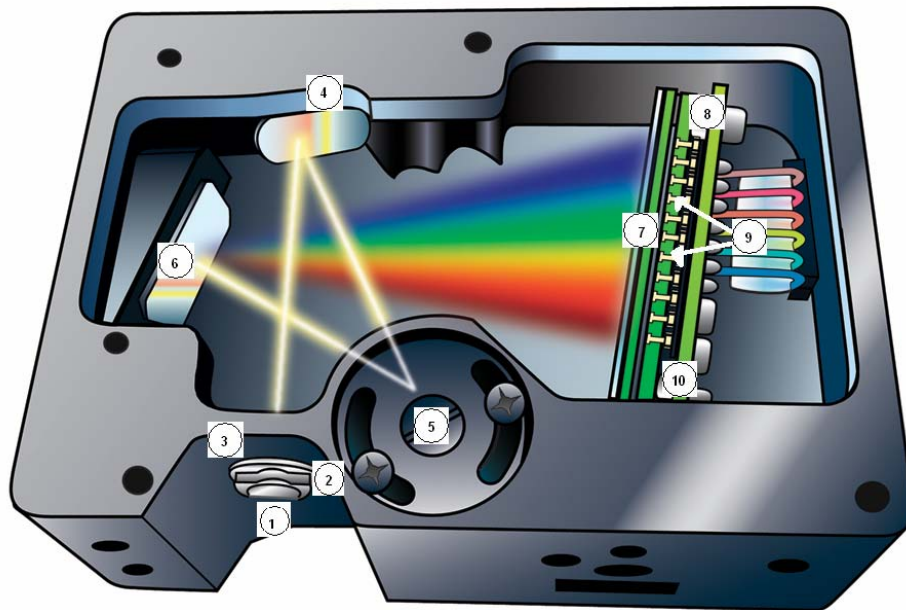

**USB2000+ Spectrometer with Components**

See [USB2000+ Components Table](#) on the following page for an explanation of the function of each numbered component in the USB2000+ Spectrometer in this diagram.

## USB2000+ Components Table

Ocean Optics permanently secures all components in the USB2000+ at the time of manufacture. Only Ocean Optics technicians can replace interchangeable components, where noted.

Item	Name	Description
1	SMA 905 Connector	Secures the input fiber to the spectrometer. Light from the input fiber enters the optical bench through this connector.
2	Slit	A dark piece of material containing a rectangular aperture, which is mounted directly behind the SMA Connector. The size of the aperture (200 $\mu\text{m}$ ) regulates the amount of light that enters the optical bench and controls spectral resolution.
3	Filter	Restricts optical radiation to pre-determined wavelength regions. Light passes through the Filter before entering the optical bench.
4	Collimating Mirror	A SAG+, Ag-coated mirror focuses light entering the optical bench towards the Grating of the spectrometer. Light enters the spectrometer, passes through the SMA Connector, Slit, and Filter, and then reflects off the Collimating Mirror onto the Grating.
5	Grating	A #3 (600 lines per millimeter, blazed at 500 nm) grating diffracts light from the Collimating Mirror and directs the diffracted light onto the Focusing Mirror.
6	Focusing Mirror	A SAG+, Ag-coated mirror receives light reflected from the Grating and focuses first-order spectra onto the detector plane.
7	L2 Detector Collection Lens	Attaches to the Detector to increase light-collection efficiency. It focuses light from a tall slit onto the shorter Detector elements. The L2 Detector Collection Lens should be used with large diameter slits or in applications with low light levels. It also improves efficiency by reducing the effects of stray light.
8	Detector	Collects the light received from the Focusing Mirror or L2 Detector Collection Lens and converts the optical signal to a digital signal. Each pixel on the Detector responds to the wavelength of light that strikes it, creating a digital response. The spectrometer then transmits the digital signal to the SpectraSuite application.
9	LVF Filters	Optional Linear Variable Filters (LVF) construct systems with excellent separation of excitation and fluorescence energy. LVF-L Linear low-pass filters fine tune the excitation source for maximum signal with minimum overlap. LVF-H high-pass filters are available for the detection side. These filters are optional.

# USB2000+ Specifications

The following table provides specification information for the USB2000+.

Specification	Value
Spectrometer	USB2000+
Grating Options	14 different gratings, UV through Shortwave NIR
Detector	2048-element linear silicon CCD array; L2 Collection Lens
Wavelength range	200-1100 nm
Entrance aperture	5, 10, 25, 50, 100 or 200 $\mu\text{m}$ wide slits or fiber (no slit)
AgPlus Mirrors	Provide reflectivity >95% over the visible and NIR wavelength range and over a wide range of angles of incidence
Integration time	1 ms to 65 seconds
Data transfer rate	Full scans (2048 wavelengths) into memory every 13 milliseconds Time acquisition approximately every 25 milliseconds
Optical resolution	$\sim$ 0.3-10.0 nm FWHM
Stray light	$\sim$ 0.05% at 600 nm, <0.10% at 435 nm
Power consumption	250 mA @ 5 VDC
Dimensions	89.1 mm x 63.3 mm x 34.4 mm
Weight	190 g
Computer interface	Universal Serial Bus (RS-232 available on side connector)
Computer requirements*	IBM-compatible PC with Pentium or better microprocessor 32 MB RAM (16 MB) Windows 98/Me/2000/XP, Mac OS X and Linux when using the USB interface on desktop or notebook PCs. Any 32-bit Windows operating system when using the serial port on desktop or notebook PCs. Windows CE 2.11 and above when using the serial port on handheld PCs.
Operating software	SpectraSuite (for an additional \$199)
Fiber optic connector	SMA 905 to single-strand optical fiber

\* Download [free software](#) to analyze your computer's USB readiness by clicking here.

## 20-Pin Accessory Connector Pinout

The USB2000+ features a 20-pin Accessory Connector, located on the front of the unit as shown:



**Location of USB2000+ 20-Pin Accessory Connector**

## 20-Pin Accessory Connector Pinout Diagram

When facing the 20-pin Accessory Connector on the front of the vertical wall of the USB2000+, pin numbering is as follows:

18	16	14	12	10	8	6	4	2	A2
17	15	13	11	9	7	5	3	1	A1

**20-Pin Accessory Connector Pinout Diagram**

## 20-Pin Accessory Connector – Pin Definitions and Descriptions

The following table contains information regarding the function of each pin in the USB2000+'s 10-Pin Accessory Connector:

Pin #	Function	Input/Output	Description
A1	SPI_CLK	Output	The SPI Clock signal for communications to other SPI peripherals
A2	SPICS_OUT	Output	The SPI Chip/Device Select signal for communications to other SPI peripherals
1	$V_{CC}$ , $V_{USB}$ , or $5V_{IN}$	Input or Output	Input power pin for USB2000+ – When operating via USB, this pin can power other peripherals – Ensure that peripherals comply with USB specifications

Pin #	Function	Input/Output	Description
2	RS232 Tx	Output	RS232 transmit signal – Communicates with a computer over DB9 Pin 2
3	RS232 Rx	Input	RS232 receive signal – Communicates with a computer over DB9 Pin 3
4	Lamp Enable	Output	TTL signal driven Active HIGH when the Lamp Enable command is sent to the spectrometer
5	Continuous Strobe	Output	TTL output signal used to pulse a strobe – Divided down from the master clock signal
6	Ground	Input/Output	Ground
7	External Trigger In	Input	TTL input trigger signal – See External Triggering Options document for info
8	Single Strobe	Output	TTL output pulse used as a strobe signal – Has a programmable delay relative to the beginning of the spectrometer integration period
9	I <sup>2</sup> C SCL	Input/Output	The I <sup>2</sup> C clock signal for communications to other I <sup>2</sup> C peripherals.
10	I <sup>2</sup> C SDA	Input/Output	The I <sup>2</sup> C Data signal for communications to other I <sup>2</sup> C peripherals.
11	MOSI	Output	The SPI Master Out Slave In (MOSI) signal for communications to other SPI peripherals
12	MISO	Input	The SPI Master In Slave Out (MISO) signal for communications to other SPI peripherals
13	GPIO-1	Input/Output	Master clock
14	GPIO-0	Input/Output	Base clock
15	GPIO-3	Input/Output	Integration clock
16	GPIO-2	Input/Output	Reserved
17	GPIO-5	Input/Output	Acquire spectra (Read Enable)
18	GPIO-4	Input/Output	Reserved
19	GPIO-7	Input/Output	SH CCD pin
20	GPIO-6	Input/Output	ICG CCD pin

## C: Specifications

---

---

# Index

## 20

20-pin accessory connector  
diagram, 22  
pin definitions, 22

## A

accessories, 4, 7  
accessory connector  
pinout, 22  
additional equipment, 4  
Adobe Acrobat Reader, 4

## C

Calibrating, iii, 13  
calibration, 13  
preparing for, 14  
procedure, 14  
calibration coefficients  
saving in USB mode, 16  
CCD Detector, 20  
collimating mirror, 20  
Components Table, 20  
configuration, 7  
configuring, 8

## D

Detector Collection Lens, 20  
document  
audience, iii  
purpose, iii  
summary, iii

## E

EEPROM, 2  
external triggering, 17

## F

features, 2  
filter, 20  
focusing mirror, 20

## G

grating, 20

## I

Installation, 6  
Serial Port mode, 7  
USB mode, 6  
installed filter, 20  
Interface, 3

## L

L2 Detector Collection Lens, 20  
Lens, 20

## M

memory chip, 2  
mirror, 20

## O

OOIBase32, 8  
Options  
Interface, 3

## P

packing list, 3  
passwords, 4  
product-related documentation, iii

## S

Sampling  
  System, 3  
Serial Port mode, 7  
service, iv  
setup, 6  
shipment components, 3  
slit, 20  
SMA Connector, 20  
Software and Resources Library CD, 4  
specifications, 19, 21  
SpectraSuite, 2  
spectroscopic accessories, 7  
System Requirements, 2

## T

Timing Diagram, 18  
triggering, 17  
troubleshooting  
  Linux systems, 11  
  Mac systems, 10  
  Windows systems, 9  
Troubleshooting, 9

## U

upgrades, iv  
USB mode, 6

## V

Variable Delay Mode, 17

## W

Wavelength Calibration  
  about, 13  
Wavelength Calibration Data File, 4  
Wavelength Calibration Data Sheet, 4